

The logo for Setpoint industrial features the word "Setpoint" in a white, italicized, sans-serif font. A white line graph with three peaks is superimposed over the letters "S", "e", and "t". Below "Setpoint" is a horizontal white line, and under that line is the word "industrial" in a white, lowercase, sans-serif font.

Setpoint
industrial

SISTEMAS & PLANTAS INDUSTRIAIS



QUEM SOMOS

Empresa brasileira provedora de soluções para alimentos e bebidas, especialista em laticínios.

O QUE FAZEMOS

Projetos, equipamentos sanitários, plantas turnkey e automação industrial.

O QUE VENDEMOS

CIPs

PASTEURIZADORES

MANIFOLDS

AQUECEDORES

PLANTAS DE PREPARAÇÃO

SISTEMAS SANITÁRIOS

PAINÉIS

SERVIÇOS

MISSÃO

Satisfazer o cliente de forma sustentável, entregando produtos de alta tecnologia e confiabilidade.

VISÃO

Ser uma empresa reconhecida no mercado nacional e internacional especialista em soluções para laticínios.

VALORES

Produzir com qualidade, respeitando nossos clientes, colaboradores, fornecedores e o meio ambiente.

CIPs



centralCIP



compactCIP



miniCIP



customCIP

centralCIP

Para limpeza de plantas industriais de médio e grande porte, com controle de pressão e vazão nos recalques, correção automática de concentração e temperatura das soluções químicas e sistema de autolimpeza dos tanques de CIP.



compactCIP

Para limpeza de áreas produtivas, recepções, tanques de estocagem e demais sistemas, onde se faz necessário o uso de equipamentos compactos.



miniCIP

Para limpeza de máquinas de envase e demais equipamentos ou áreas, onde não se faz necessária a recuperação das soluções químicas.

Setpoint
industrial



customCIP

Sistema de limpeza customizado para utilização em equipamentos e projetos especiais.



PASTEURIZADORES



Pasteurizadores

Sistemas automáticos de pasteurização de 1.000l/h até 60.000l/h para leite, iogurte, leite concentrado, soro, creme de leite, entre outros produtos.



MANIFOLDS



Manifolds

Manifolds compostos por válvulas automáticas, utilizados para distribuição de produtos líquidos no processo industrial, através do alinhamento de rotas entre origem e destino.



AQUECEDORES



Aquecedores

Sistemas automáticos de aquecimento de leite, produtos lácteos em geral e água. Montados em skids, com aquecimento através de trocadores de calor ou resistências elétricas.



Setpoint
industrial



PLANTAS DE PREPARAÇÃO



Preparação, Formulação e Mistura

Sistemas automáticos para preparação, mistura de produtos e formulação de ingredientes.



SISTEMAS SANITÁRIOS



Recepção de Leite



Desaerador Lácteos



Transf. de Creme

Recepção de Leite

Para recebimento de leite com controle de vazão, totalização e temperatura. Sistema de filtros com troca automática, através do monitoramento de pressão.



Desaerador para Lácteos

Para desaeração de requeijão ou demais produtos lácteos densos, bombeados através de bomba de deslocamento positivo e bomba centrífuga para limpeza CIP.



Setpoint
industrial



Transferência de Creme

Para resfriamento e transferência de creme de leite de uma ou mais centrífugas, bombeados através de bomba de deslocamento positivo e bomba centrífuga para limpeza CIP.



PAINÉIS



Painéis Elétricos, Automação e Pneumáticos

Painéis QGBTs, QDFs, QDLs, CCMs,
painéis de controle e painéis pneumáticos.
Atendendo as normas NBR-5410, NR-10
e NBR IEC 60439-1.



SERVIÇOS

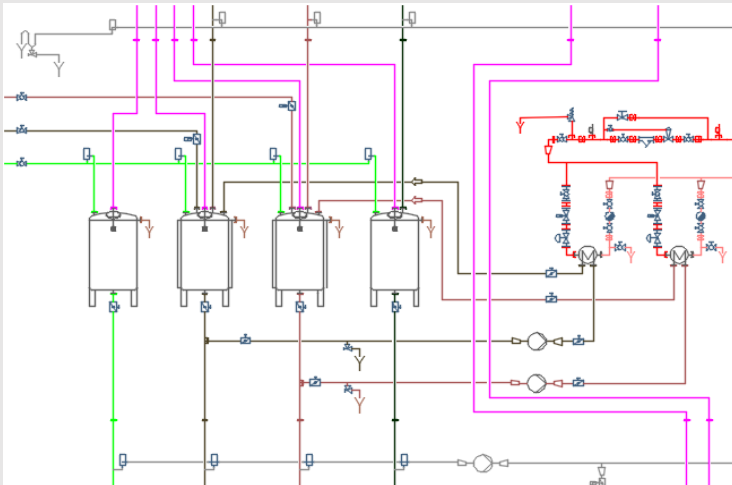

Projetos

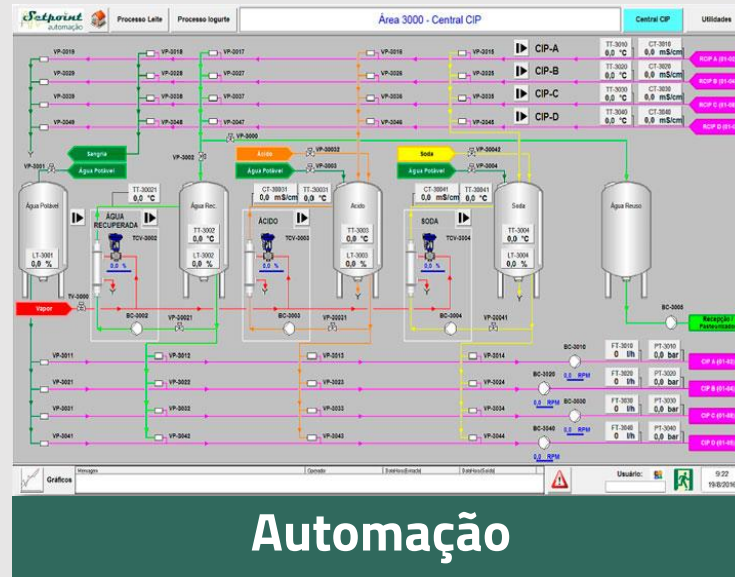

Automação



Instalações Sanitárias

Projetos

Desenvolvimento de projetos multidisciplinares para as áreas de processamento e utilidades.

Dimensionamento e especificação de equipamentos, componentes, materiais de interligação eletromecânica, instrumentação e redes de comunicação.

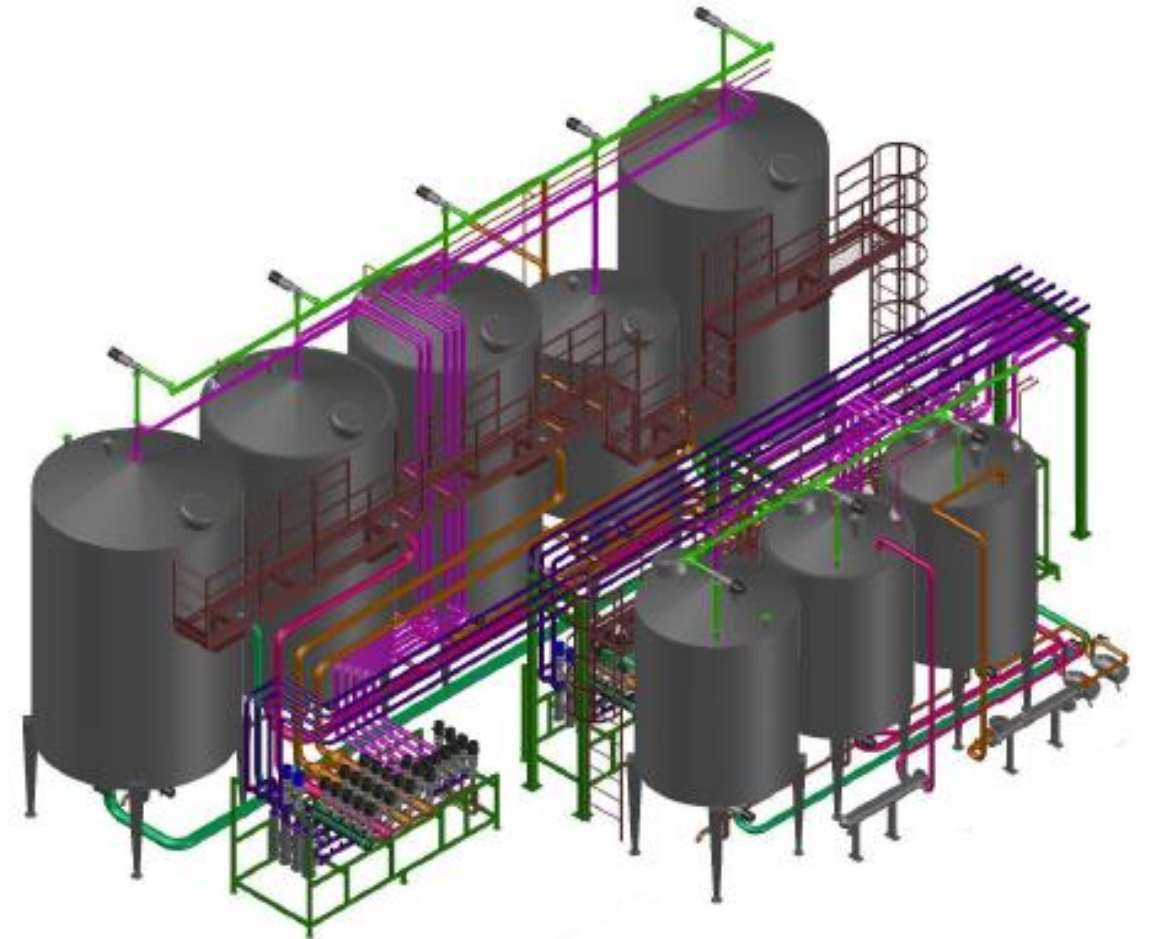
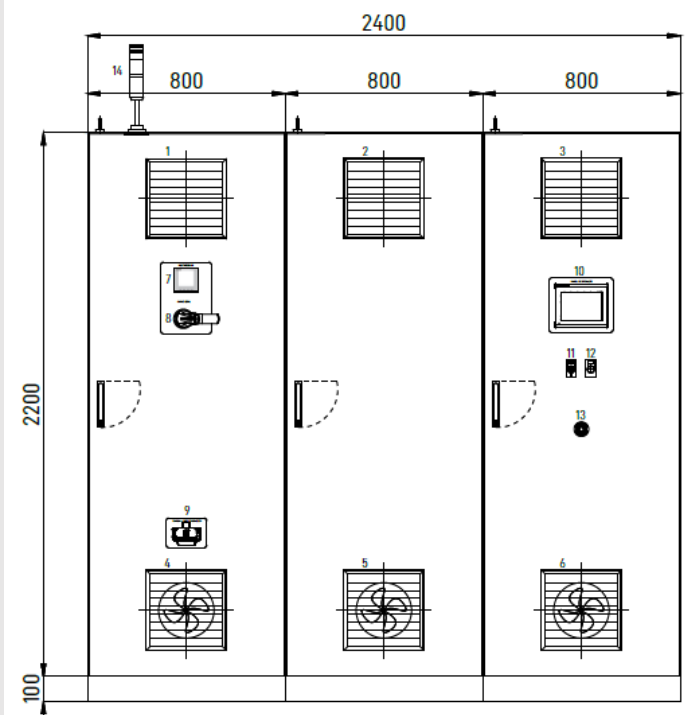

Automação

Sistemas completos de automação para controle de plantas industriais e equipamentos de processo, sistemas supervisórios e sistemas de rastreabilidade.

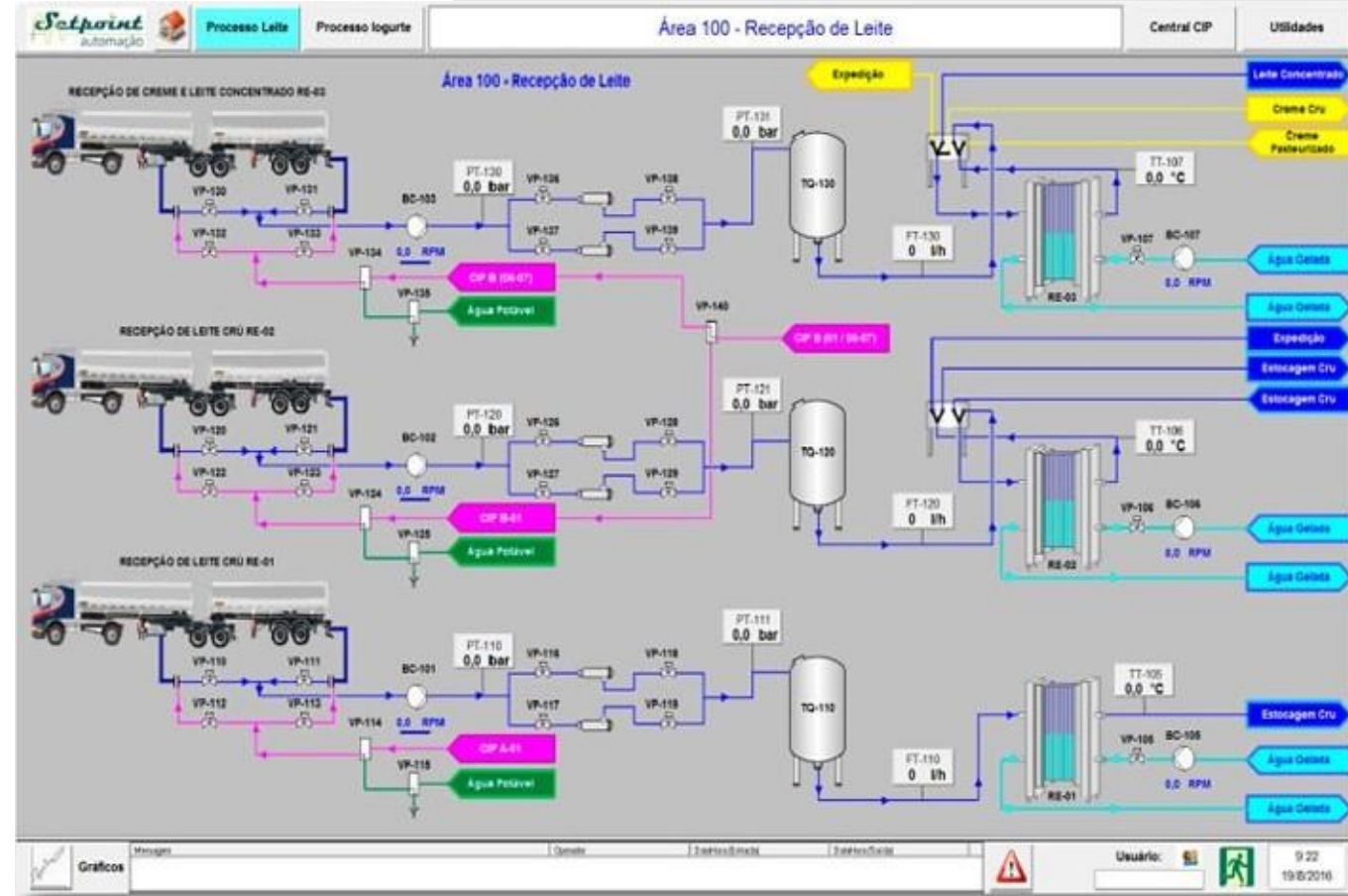
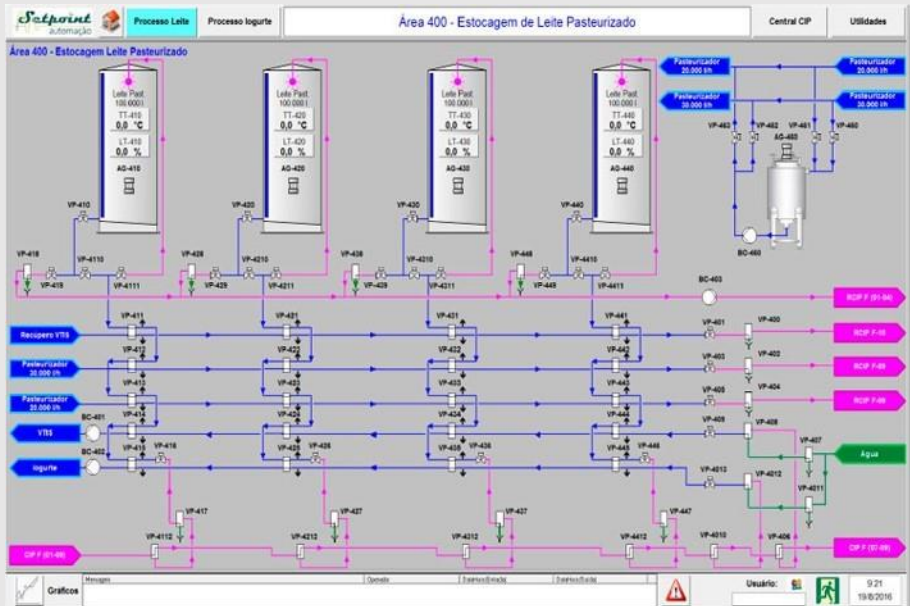

Instalações Sanitárias

Instalações eletromecânicas sanitárias para redes de utilidades, produto e CIP. Interligando as áreas de recepção, estocagem, pasteurização e demais áreas produtivas.



CLIENTES

ALIMENTOS EM GERAL, LEITE E DERIVADOS



VIGOR

LACTALIS
DO BRASIL



POLENGHI



DAUS

AB | BRASIL

KERRY



TIROL
desde 1974

DANUBIO



RICH'S



Italac

Marajoara



Siol
alimentos

Indulacsa
INDUSTRIA LÁCTEA SALTERA S.A.



FAZENDA
Bela Vista

Cativa



CLIENTES OUTROS MERCADOS



L'ORÉAL
BRASIL

grupo boticário

 GALDERMA

Ypióca
SINCE 1944

 aspen
P H A R M A

AMGEN

 GRUPO
CENTROFLORA
Parcerias para um mundo melhor.

GRUPO
INFRALAB

 suez

 cleanwater[®]
tratamento de água



CHEMLUB

spirax
sarco

 **BERMO**[®]
A COMPANY OF THE  GROUP

 **Piovan**
Piovan Group

 **SIG**

 **CNPem**
Centro Nacional de Pesquisa
em Energia e Materiais

INSTITUTO MAUÁ DE TECNOLOGIA
 **MAUÁ**

 **FUNCAMP**
FUNDAÇÃO DE DESENVOLVIMENTO DA UNICAMP

 **ASN**
TECHNOLOGIES

Obrigado!

 Marcos Uscello

 +55 19 99862-6628

 marcos@setpointindustrial.com.br

 setpointindustrial.com.br



**EMPRESA COM RECONHECIMENTO
NACIONAL E INTERNACIONAL**

Setpoint
industrial

**COMPANY WITH NATIONAL AND
INTERNATIONAL RECOGNITION**



SETPOINTINDUSTRIAL.COM.BR